

## Axial joints similar to DIN 71802

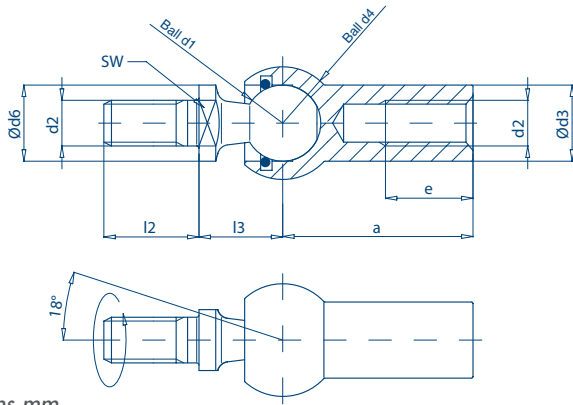

Series  
**AXA**

\*\*tolerances d2: ball stud 6g - f-threaded hole 6H

Dimensions mm

DESIGNATION	d1	d2	a	d3	d4	d6	e	l2	l3	*sw	weight (kg)
	h9	6g/6H**	±0,3	±0,5	±0,5	h14	min.	±0,3	±0,3	h14	≈
AXA 8 M5	8	M5	22	8	12,8	8	10,2	10,2	9	7	0,015
AXA10 M6	10	M6	25	10	14,8	10	11,5	12,5	11	8	0,025
AXA13 M8	13	M8	30	13	19,3	13	14	16,5	13	11	0,053
AXA16 M10	16	M10	35	16	24	16	15,5	20	16	13	0,104
AXA16 M12	16	M12	35	16	24	16	15,5	20	16	13	0,150
AXA19 M14x1,5	19	M14x1,5	45	22	30	19	21,5	28	20	16	0,221
AXA19 M14x2	19	M14	45	22	30	19	21,5	28	20	16	0,221
AXA19 M16	19	M16	45	22	30	19	21,5	28	20	16	0,221

For left-hand thread add "LH" (ex. AXA16 M10 LH)  
Technical reading from page 68 to page 69

### MATERIAL

**Ball stud:** carbon steel with tensile strength of 60 daN/mm<sup>2</sup> and a ball tempered on the surface with hardness ≥ 52 HRC stainless steel AISI 303 (1.4305) on request

**Ball socket:** steel 11SMnPb30 with tensile strength of 50 daN/mm<sup>2</sup> (1.0718) stainless steel (1.4305 - AISI 303) upon request

**Internal snap ring "R":** steel for springs C98 UNI EN 10270-1 DH stainless steel (1.4319 - AISI 302) upon request

### Surface protection:

- Zinc plating according to EN ISO 4042, Fe/Zn 8c...
- Chromate treatment (passivation) example: type A please add 1A (ex.: AXA 10 M6 1A)
- Surface treatment table at page 6

### Tolerances:

The dimensional tolerances in the table make reference to zinc plated products.

## Neoprene sealing cup for axial joints "AXA" similar to DIN 71802

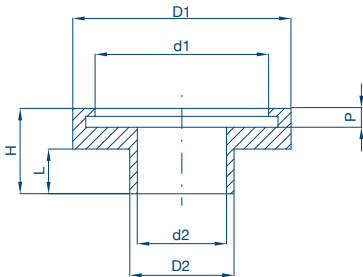

DESIGNATION	Ø	D1	d1	D2	d2	H	L	P
NEOPRENE SEALING CUP	8	11,5	9	5,4	4	4,5	1,5	1,5
NEOPRENE SEALING CUP	10	13	10,5	6,9	5,5	6,5	3,5	1,5
NEOPRENE SEALING CUP	13	17	14	8,6	7	7,5	3,5	2
NEOPRENE SEALING CUP	16	21	17,5	10,5	9	8,5	4,5	2
NEOPRENE SEALING CUP	19	25	20	14,5	13	10	6	2

AXIAL JOINTS AND SEALING CUPS

chiavette unificate